

INNOVA

SLEEP SYSTEMS

OWNER'S MANUAL

Royal Plus

KN04R5N:3+4+6





Table of Contents

Precautions 3

Parts List 6

Installation Guide 7

Remote Control Instructions 12

Programming Memory Positions 13

Synchronizing Remote..... 15

Warranty Info..... 16

Troubleshooting 20

PRECAUTIONS

WARNING

Read the following information before using this product. Failure to adhere to these terms and precautions could compromise safety, cause product malfunction and/or void a portion of your warranty.

Electrical power surges are a leading cause of problems with electrical circuits. In order to help protect your investment in case of a power surge or outage, use an electrical surge protection device (not included).

WARRANTY WARNING!

Do not open or tamper with the transformer, control box, motors, or remote control (with the exception of opening battery compartments as necessary). Your product warranty will be void if these components are tampered with.

Do not remove the law label attached to the base of this product. Removing the law label may delay the processing, or void all or a portion, of your warranty claim.

SMALL CHILDREN AND PETS:

Immediately dispose of all packing materials as they can smother, choke, or otherwise harm small children and pets. Do not allow any person or pets under the bed. Children, convalescents, and disabled persons should not operate the bed without adult supervision.

HOSPITAL OR CONVALESCENT USE DISCLAIMER:

This adjustable base is designed and engineered for a lifestyle of in-home comfort and not intended for hospital use, for a bed-ridden persons, or for an extended recovery. This product is not equipped with bars to help persons get safely in and out of bed and is not intended for use around tent type oxygen therapy or explosive gases.

MINIMUM LEG HEIGHT:

The minimum leg height is 4". Using this product without legs or with legs shorter than 4" will void the warranty.

PRODUCT RATINGS:

The product's lift motors are not designed for continuous use of more than 2 minutes in an 18 minute period, or approximately 10% duty cycle. For every 30 minutes the massage motor is used, the massage motor needs 30 minutes of rest. The massage function should be used for a maximum of 2 hours in a 12 hour period. Any attempt to circumvent or exceed this rating will shorten the life expectancy of the product and may void the warranty.

WEIGHT LIMITS:

The limitation for this product is 950 lbs. This product will structurally support up to 950 lbs, provided the mattress is evenly distributed across the product and the weight isn't concentrated in one area. This product is not designed to support or lift such amounts in the head or foot section alone. Exceeding this weight restriction will void the warranty and could damage the bed and/or cause injury. Enter and exit the bed in a flat position and do not sit on the head or foot sections while this product is in the raised position.

ELECTRONIC MECHANISMS:

It is normal for the raising and lowering feature of this product to emit a minimal humming sound during operation. The massage feature creates a vibrating hum during operation and the resonance will increase accordingly with a higher intensity motor setting.

LOCATION ENVIRONMENT:

The level of sound experienced in a room is directly related to the environment within that location. In a room with hardwood floors and the massager turned on, a vibrating noise may be noticeable. Placing a piece of carpet or rubber casters cups under the legs of the product may reduce this resonance. The rubber caster cups also prevent the product from sliding when located on smooth or hard surface flooring.

TO REDUCE THE RISK OF SHOCK, BURNS, FIRE OR INJURY:

Make sure the product is in the flat position before unplugging from power source. Always unplug the product from the electrical outlet before cleaning or servicing the product. If the cord or plug is damaged, document the damage and contact customer service for advisement on continued use.

MANUAL VERSION: 102001

FCC COMPLIANCE:

This device complies with part 15 of the FCC Rules for residential use. Operation is subject to the following two conditions: (1) This device may not cause harmful interference, and (2) this device must accept any interference received, including interference that may cause undesired operation.

Radio Frequency: 2.4 GHz

EMERGENCY BATTERY BACKUP:

In the event that the product is stuck in an articulated position during a power outage, the battery backup in the transformer will return the product to the flat position. To do this, install two new 9-volt alkaline batteries into the battery compartment of the transformer. Use the reset button on the control box or the extension cord from the control box to the transformer to return the base to the flat position. Remove batteries after lowering.

Batteries should not be used for normal operation of the product.

PARTS LIST

Step 1:

Check and verify all parts are included before discarding any packing materials. All electronics and components that need to be installed are located in boxes under the base or attached to the frame.

 <p>A) Wireless Remote</p>	 <p>B) Mattress Retainer Bar (1)</p>	 <p>C) Legs (7)</p>	
 <p>D) Power Cord (1)</p>	 <p>E) Transformer (1)</p>	 <p>F) Control Box (1)</p>	 <p>G) Leg Spacer (1)</p>

Important: We strongly recommend two able-bodied adults setup and assemble this product.

SET UP & INSTALLATION

Step 2:

With two able-bodied people, place carton on floor and remove the lid on the box.



Step 3:

It is recommended to test the bed while still in the box before fully setting up.

- Connect the Transformer “E” to Control Box “F”. (The Control Box is the black box attached to the bottom of the bed.)
- Plug the power cable from the Control Box “F” into the short electrical output cord on Transformer “E”.
- Extend the Power Cord “D” and plug it into the Transformer “E”. (See Figure 1)

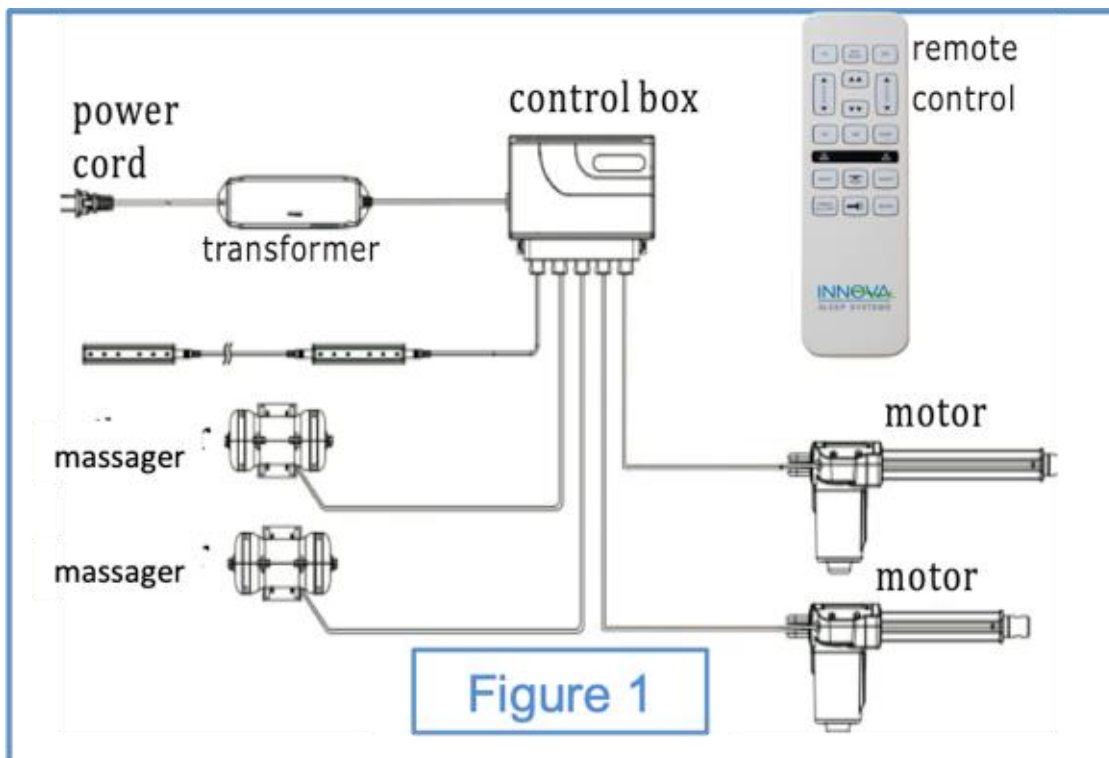

Step 4:

Locate the Wireless Remote control and insert 2 AAA batteries (not included). See Figure 2.



Figure 2

Step 5:

Plug the Power Cord into a grounded electrical outlet. A surge protector is recommended. Using the Wireless Remote, push the HEAD UP button, then push the FOOT UP button, and then the vibrating motors for a momentary test of the Wireless Remote (Figure 3). If the motors are working, skip to step 7.



Figure 3

WE STRONGLY RECOMMEND:

In order to help protect your investment in case of a power surge or outage, use an electrical surge protection device with a battery backup system (not included) and plug it in to a grounded outlet.

Step 6:

Synchronize the Wireless Remote with the Control Box:

Press HEAD UP and FOOT UP buttons simultaneously, then press the RESET button (See Fig. 4) on the side of the Control Box or on the Extension Cord. You will hear some quick beeping sounds.

The adjustable bed should work after syncing the Wireless Remote with the Control Box. Press the HEAD UP button to test.

The RESET button also can be used to lower the bed base to flat. When pressed once, it adjusts bed to the flat position.

To sync two remotes to one bed, follow directions on page 17.



Figure 4

Step 7:

Unplug the Power Cord.

Install the seven legs firmly into the base of the frame. The legs screw into the threaded holes around the perimeter of the adjustable base frame (See Figure 5).

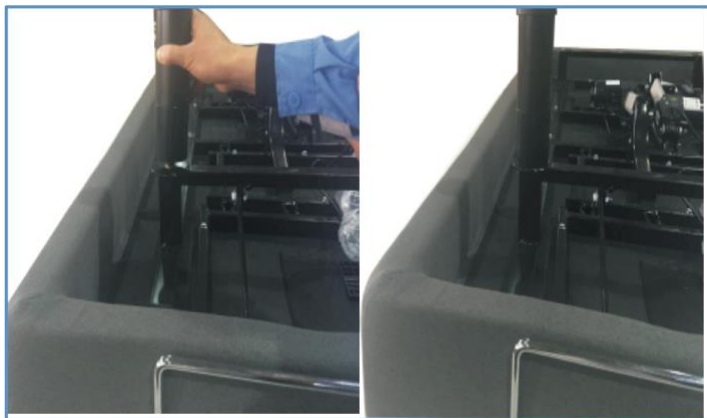

Figure 5

For the leg in the center of the bed, screw in spacer and then the leg (See Figure 6)

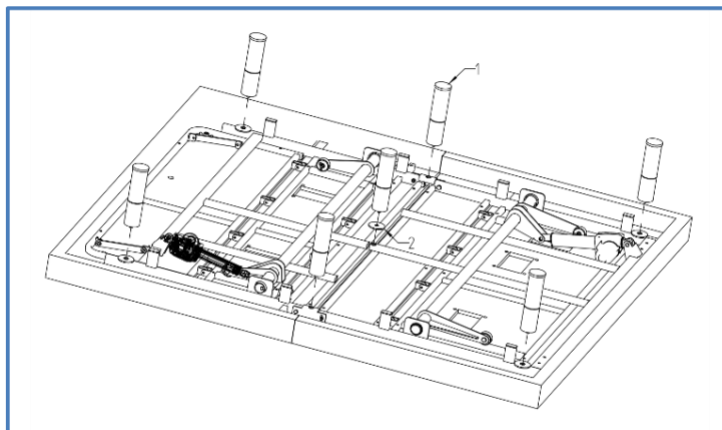

Figure 6

The legs are stackable and are 3", 4" and 6". The combination gives you a set of six 3", 4", 6", 7", 9", 10", or 13" legs. The minimum height for this base is 4".

Do not over tighten.

Step 8:

Assemble the connecting hinge in the middle of the base on each side as shown in Figure 7.

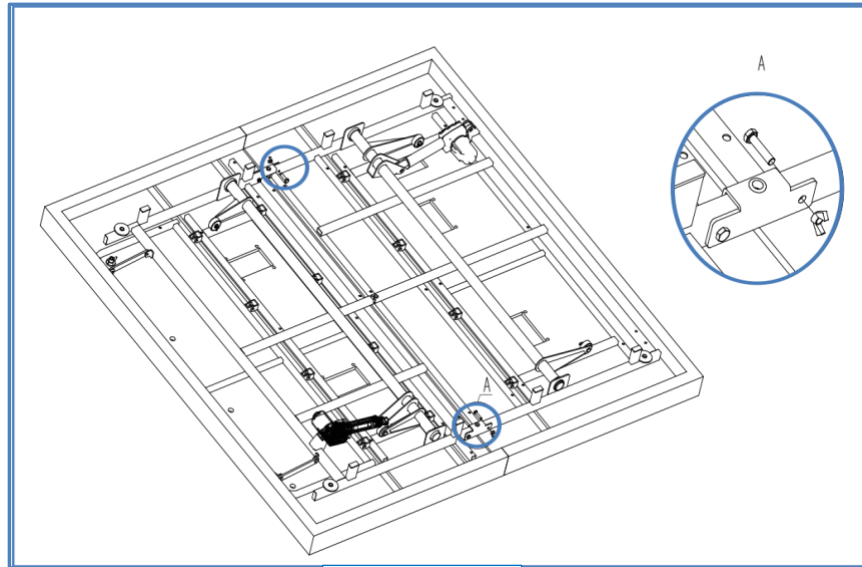

Figure 7

Step 9:

Remove the plastic clip from above the wire inputs on the Control Box (Figure 8). Plug in the foot lift motor cord (Figure 9) and the foot massager (Figure 10). Replace clip (Figure 11).



Figure 8



Figure 9

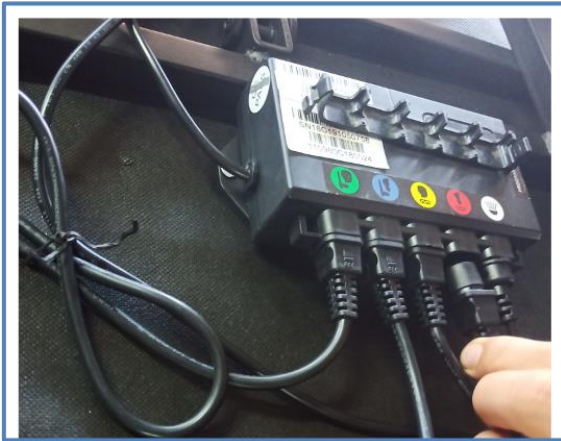

Figure 10

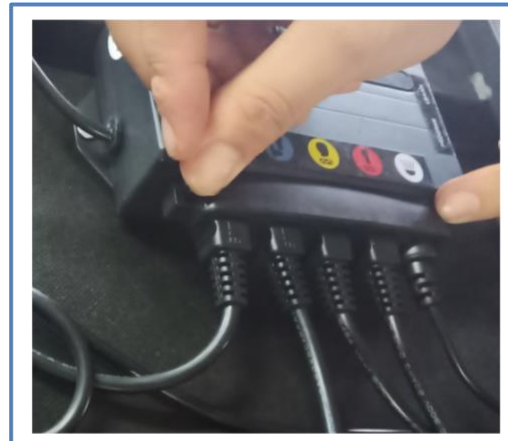

Figure 11

Step 10:

With the help of your able-bodied assistant, carefully lift the adjustable bed frame and set it in place upright on its legs. Excessive pressure and dragging the bed without lifting may damage the legs. Remove all protective plastic covering.

Note: Check and make sure that all power cords are untangled and do not interfere with any adjustable bed mechanisms.

Dispose of covering properly to avoid injury.

Step 11:

Note: The Mattress Retaining Bar is tied to the underside of the base for shipping. Install the Mattress Retaining Bar upright by carefully aligning and pushing the bar into place.

Insert the Mattress Retaining Bar into the holders at the foot of the bed. (Figure 12)

The Mattress Retaining Bar prevents the mattress from slipping off the base and should not be used as a handle of the base. Using as a handle will damage the retaining bar holders. Screws come out from the retainer bar holders will be considered as a damaged part and not a defective part and is not covered by the warranty.



Figure 12

Setup is now complete.

Plug your base back in and enjoy your new adjustable bed.

Wireless Remote Instructions

For toll-free customer service, call 1-877-386-1373 (US) or 1-833-486-8334 (Canada)
or email us: service@innovasleep.com

Please tell us your name, phone, address, Model Name and/or Model ID (found on the law label tags, which are stapled to the head of the base), purchase date, and the question or concern when you call/email.

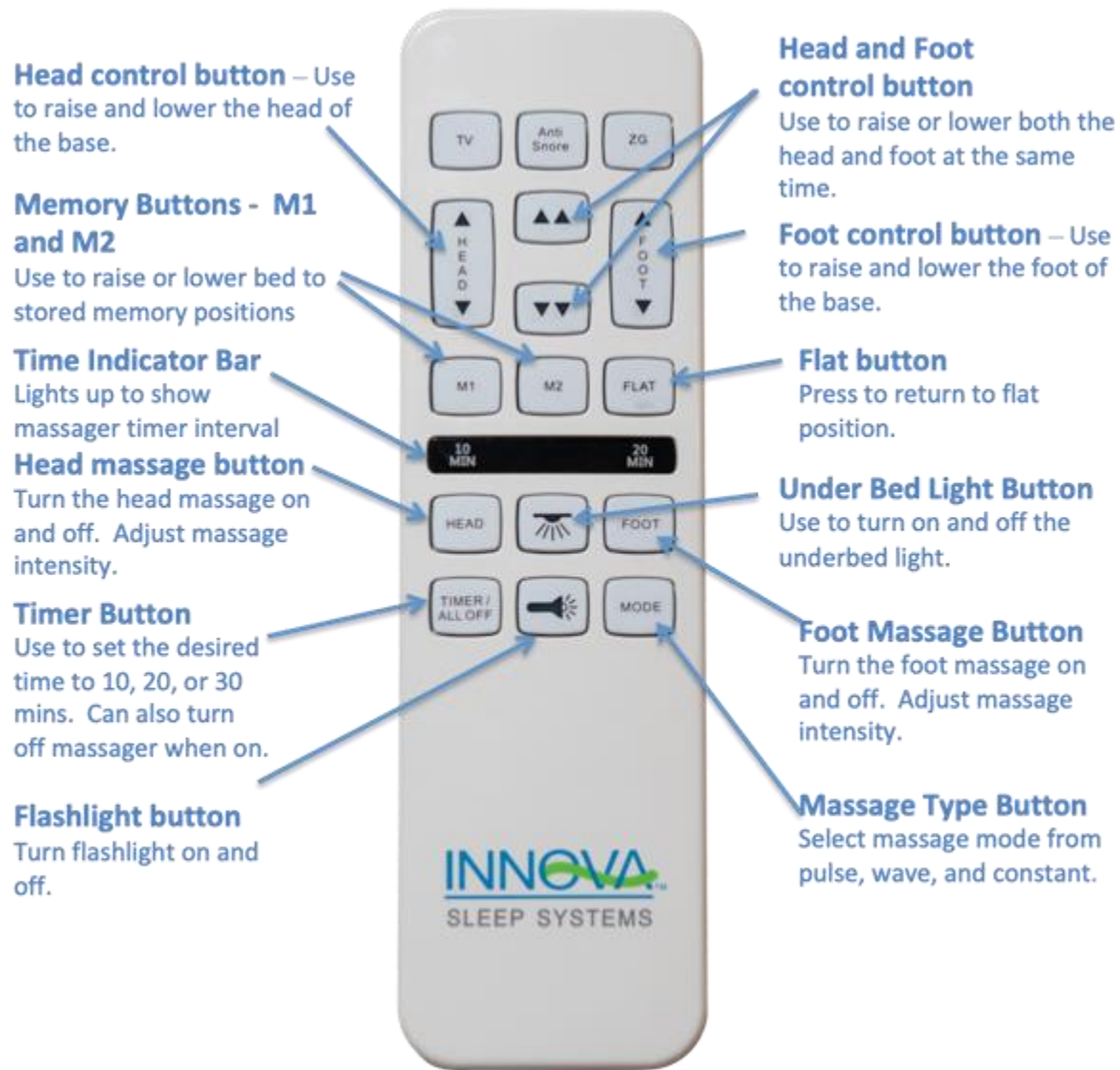

Figure 13

How to Program Memory Position Buttons:

The remote has 5 memory buttons: "TV", "Anti-Snore", "ZG", "M1", and "M2". These positions have been tested but have not been preprogrammed, as each user will have his/her own individual preferences.

1. In order to set each button, adjust the bed to the desired position.
2. Press and hold the memory button until the backlight on the remote flashes to confirm that setting has been saved.
3. Each of the 5 position buttons (M1, M2, TV, Anti-Snore, or ZG) can be reset by repeating steps 1 and 2.



Figure 14

The "TV", "Anti-Snore", and "ZG" labels are suggestions for memory positions. We recommend that the "TV" position be set in the most comfortable position for watching TV or reading. We recommend that the "Anti-Snore" position be set where the head is slightly elevated while comfortable for sleeping. ZG stands for Zero Gravity; the zero gravity position is defined by the head and legs being slightly above the heart.

How to Set and Remove Child Safety Locks:

The Child Safety Locks prevent the head and foot of the bed from moving from current settings until they are turned off. When the Child Safety Locks are engaged, the Remote will not sync to the Control Box.

Child safety locks:

Press the head down and foot up button simultaneously until the backlight flashes to lock and unlock



Figure 15

USING 2 REMOTES ON SAME BED

- Press the HEAD DOWN and FOOT DOWN button of a new Remote B (that has not previously been synced with the beds) until the light flashes.
- Release the two buttons. The flashlight will be on for 10 seconds.
- Press the HEAD UP and FOOT UP button of the Master Remote A. The cloning process is successful when the flashlight of Remote B starts to blink.
- Now both Wireless Remotes will be able to control both beds. (See Figure 16)



To desynchronize the Clone Remote B from Master Remote A, press the HEAD AND FOOT CONTROL buttons of the Clone Remote B. The desynchronizing process is successful when the Clone Remote B starts to blink. (See Figure 17)



INNOVA SLEEP PRODUCT 1, 3 & 20 YEAR LIMITED WARRANTY

YOUR INNOVA ADJUSTABLE BED BASE (the “Product”) IS COVERED BY THE LIMITED WARRANTY SET FORTH HEREIN.

THIS LIMITED WARRANTY GIVES YOU SPECIFIC LEGAL RIGHTS, AND YOU MAY ALSO HAVE OTHER RIGHTS WHICH VARY FROM STATE TO STATE.

WE WARRANT THAT DURING THE APPLICABLE WARRANTY PERIOD, THE PRODUCT WILL BE FREE FROM DEFECTS IN MATERIALS AND WORKMANSHIP.

INNOVA’S RESPONSIBILITY FOR DEFECTIVE PRODUCTS IS LIMITED TO REPAIR OR REPLACEMENT AS DESCRIBED BELOW.

WHO MAY USE THIS WARRANTY?

Innova Sleep Products, Inc. (“Innova”) extends this limited warranty only to the consumer who is the original purchaser of a new Product (the “Purchaser”). It does not extend to any subsequent owner or other transferee of the Product. Floor model Products and Products sold expressly “as is” are not covered by this limited warranty.

WHAT DOES THIS WARRANTY COVER?

This limited warranty covers defects in materials and workmanship of the Product for the applicable Warranty Period specified below.

WHAT IS NOT COVERED BY THIS WARRANTY?

This limited warranty does not cover any damage due to: (i) transportation, (ii) storage, (iii) improper use, such as use other than personal use in-home exclusively by the Purchaser, (iv) failure to follow the Product operation and maintenance instructions in the Owner’s Manual, this limited warranty, or the Product Precautions, (v) modifications, (vi) unauthorized repair, (vii) normal wear and tear, and/or (viii) external causes such as accidents, abuse, or other actions or events beyond Innova’s reasonable control. This limited warranty also does not cover (a) damage to any products or materials used with, but not constituting or comprising, a Product (including but not limited to mattresses, fabric, cables, electrical cords or items supplied by dealers), (b) the costs of service calls unrelated to any defect (such as in connection with removal, installation, setup, in-home service calls solely for the purpose of educating the Purchaser about the Product or assistance with locating appropriate power connections), and/or (c) reimbursement for inconvenience, loss of use or any other costs or expenses.

WHAT IS THE PERIOD OF COVERAGE?

This limited warranty commences on the Purchaser's date of purchase and lasts for the periods set forth below (the "Warranty Period"), and will not be extended if Innova repairs or replaces any Product or part:

Part Name	Parts Warranty Period	Labor Warranty Period
Motor	3 Year	1 Year
Transformer(s)	3 Year	1 Year
Remote Control	1 Year	1 Year
Control Box(es)	3 Year	1 Year
Frame	20 Year	20 Year

WHAT ARE THE PURCHASER'S REMEDIES UNDER THIS WARRANTY?

Year One: Full Labor and Parts Coverage

With respect to any defective Product or part thereof (as listed above) during the first year of the Warranty Period, Innova will, in its sole discretion, either: (i) repair such Product (or the defective part) free of charge to the Purchaser, or (ii) replace the Product (or the defective part) with new or refurbished Product(s) or part(s) free of charge to the Purchaser. Innova will pay all authorized labor and transportation costs associated with any such repair or replacement.

Years Two and Three: Limited Parts Coverage

With respect to any defective Motor, Transformer, Control Box or Frame part(s) during the second and third years of the Warranty Period, Innova will, in its sole discretion, either: (i) repair such Product (or the defective part) free of charge to the Purchaser, or (ii) replace the Product (or the defective part) with new or refurbished Product(s) or part(s); provided, however, that the Purchaser shall be responsible for the cost of all authorized labor and transportation costs associated with any such repair or replacement. This limited warranty shall not apply if the Purchaser does not return any and all defective parts to Innova promptly following Innova's request.

Years Four through Twenty: Limited Frame Coverage

With respect to any mechanical part of the Product frame found to be defective during the fourth through twentieth years of the Warranty Period, Innova will, in its sole discretion, either: (i) repair such part free of charge to the Purchaser, or (ii) replace the defective part(s) with new or refurbished Product(s) or part(s); provided, however, that the Purchaser shall be responsible for: (a) all transportation costs associated with any such repair or replacement and (b) if the Product is replaced, the Purchaser shall pay to Innova an amount equal to one-twentieth (1/20) of the then-current replacement cost, times the number of years that have elapsed during the Warranty Period as of the time

the warranty claim is made. This limited warranty shall not apply if the Purchaser does not return any and all defective parts to Innova promptly following Innova's request.

HOW CAN THE PURCHASER OBTAIN WARRANTY SERVICE?

To obtain warranty service, the Purchaser must call 1-877-386-1373 (US) or 1-833-486-8334 (Canada) or email Innova customer service at service@innovasleep.com during the Warranty Period. No warranty service will be provided, nor may any warranty claim be made, without: (i) the law label tags (see below for information on locating the law labels), and (ii) a sales receipt/proof of purchase showing the date of purchase, the amount paid and the place of purchase.

Innova and/or its service technicians shall not be responsible for moving furniture or any other items not attached to the Product in order to perform service on the Product. It is the sole responsibility of the Purchaser to provide adequate space and accessibility to the Product. In the event that Innova is unable to perform service due to lack of accessibility, the service call will be billed to the Purchaser and the service will have to be rescheduled.

Finding the Law Label

The law label is needed to verify all warranty claims. To locate the law label tags, use remote to bring head of base all the way up so that the base is in the below position:

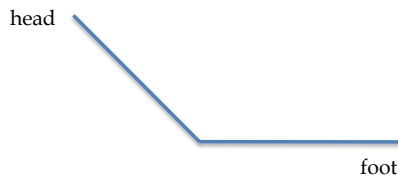

The law label is stapled to the head of the Product base as seen below:



Manufactured By:
Cixi Star Alliance Smart Furniture Co.,Ltd
No.988 Cidong North Avenue, Coastal
Economic Development Zone,
Cixi City,Zhejiang Province,China

Date of Manufacture:

Importer/U.S. Records Location:
Innova Sleep Systems Inc.
2290 Huntington Drive, Ste 200
San Marino, CA 91108.

Model ID: ROYAL PLUS
Prototype ID: Multiple
Foundation ID: ROYAL PLUS

WARNING:
This product can expose you to
chemicals including Di(2-ethylhexyl)
phthalate (DEHP), which are known to the
State of California to cause cancer or birth
defects or other reproductive harm. For
more information go to
www.P65Warnings.ca.gov.

UNDER PENALTY OF LAW THIS TAG NOT TO BE REMOVED EXCEPT BY THE CONSUMER
ALL NEW MATERIAL consisting of 100% polyurethane foam...8% EPE...9% plywood made of Poplar...89%
REG. NO. CA 45537(CN)
Certification is made by the manufacturer that the materials in this article are described in accordance with law.
MADE FOR INNOVA SLEEP SYSTEMS INC 2290 Huntington Drive, Ste 200 San Marino, CA 91108.
Date of Delivery:
Finished Size: L 79.5" X W 59.5"
Cover: 100% polyester
MADE IN CHINA

LIMITATION OF LIABILITY; DISCLAIMERS

THE REMEDIES DESCRIBED ABOVE ARE THE PURCHASER'S SOLE AND EXCLUSIVE REMEDIES AND INNOVA'S ENTIRE LIABILITY UNDER THIS LIMITED WARRANTY. INNOVA'S LIABILITY SHALL UNDER NO CIRCUMSTANCES EXCEED THE ACTUAL AMOUNT PAID BY THE PURCHASER FOR THE DEFECTIVE PRODUCT, NOR SHALL INNOVA UNDER ANY CIRCUMSTANCES BE LIABLE FOR ANY CONSEQUENTIAL, INCIDENTAL, SPECIAL OR PUNITIVE DAMAGES OR LOSSES, WHETHER DIRECT OR INDIRECT.

SOME STATES DO NOT ALLOW THE EXCLUSION OR LIMITATION OF INCIDENTAL OR CONSEQUENTIAL DAMAGES, SO THE ABOVE LIMITATION OR EXCLUSION MAY NOT APPLY TO CERTAIN PURCHASERS.

THE EXTENT PERMITTED BY LAW, THIS WARRANTY AND THE REMEDIES SET FORTH HEREIN ARE EXCLUSIVE AND IN LIEU OF ALL OTHER WARRANTIES, REMEDIES AND CONDITIONS, WHETHER ORAL, WRITTEN, STATUTORY, EXPRESS OR IMPLIED, INCLUDING WITHOUT LIMITATION, WARRANTIES OF MERCHANTABILITY AND FITNESS FOR A PARTICULAR PURPOSE AND WARRANTIES AGAINST HIDDEN OR LATENT DEFECTS. IN SO FAR AS SUCH WARRANTIES CANNOT BE DISCLAIMED, INNOVA LIMITS THE DURATION AND REMEDIES OF ALL IMPLIED WARRANTIES, INCLUDING WITHOUT LIMITATION, THE WARRANTIES OF MERCHANTABILITY AND FITNESS FOR A PARTICULAR PURPOSE TO THE DURATION OF THIS WRITTEN WARRANTY.

SOME STATES DO NOT ALLOW EXCLUSIONS OR LIMITATIONS ON HOW LONG AN IMPLIED WARRANTY MAY LAST, SO THE ABOVE LIMITATION MAY NOT APPLY TO YOU.

TROUBLESHOOTING

Remote doesn't light up or bed works intermittently

- a. Change the batteries with **2 AAA lithium batteries of any brand**.
- b. If your base does not work after changing the batteries, check to see if there is a green light on the Transformer, which is the black box on the floor that is attached to the Power Cord that plugs in to the surge protector or wall. Bases should be plugged into a surge protector.

Remote doesn't control the bed base

If the green light on the Transformer is **ON**

- Check the connections between the Transformer and the Control Box as well as the connections between the Control Box and the actuators.
- Sync bed to the base as described in Step 6 (Page 9). Make sure you are continuing to hold the HEAD UP and FOOT UP buttons on the Remote **before** you press the blue RESET button.
- If you have followed the process outlined in Step 6 using the easy-to-reach RESET button and your Remote still will not operate your base, locate the Control Box and find the RESET button on the Control Box. Repeat the process in Step 6 using the RESET button on the Control Box.



- Verify the Child Safety Locks are not engaged. When engaged, the backlight on the Remote will flicker.
 - Press and hold the HEAD DOWN arrow and the FOOT UP arrow until the Remote blinks to deactivate the Child Safety Locks. If the base then moves, the Child Safety Locks have been successfully taken off.
 - Repeat Step 6 (Page 9) to sync the now unlocked Remote using either RESET button.

Note: Pressing the HEAD DOWN and FOOT UP buttons at the same time will toggle the Child Safety Locks Off/On. If this does not fix the issue, the Child Safety Locks may now be on. You will then need to press the same two buttons again to turn them back off.

If the green light on the Transformer is **NOT ON**:

- Check the connection between the Power Cord and Transformer.
- Please unplug your base for 30 minutes and plug it back in and see if the light comes back on.
 - If it does, follow directions for when the green light is on.

If you are unable to use your Remote, the blue RESET button on the Control Box or Power Cord can be used to lower your bed base to flat as long as the green light on the Transformer is on.



**For toll-free customer service, call 1-877-386-1373 (US) or
1-833-486-8334 (Canada) or email
service@innovasleep.com**

Please tell us your name, phone, address, Model Number/ID (found on the law label tags, which are stapled to the head of the base), purchase date, and the question or concern when you call or email.

A bed that moves you.

