



SLEEP SYSTEMS

PB170 Wired Adjustable Base



Owner Manual

CONTENTS

Advisory

Setup and Installation

Wired Hand Control

1-2-20 year Warranty

Manufactured by Innova Sleep Systems

1-14

WARNING

Attention: Read the following information before using this product . Failure to use a surge protection device could compromise safety or cause product malfunction and could void the electrical portion of your warranty.

Electrical surges are by far the biggest cause of problems with electrical circuits.

In order to help protect your investment in case of a power surge or outage, use an electrical surge protection device (not included).

WARRANTY WARNING!

Do not open or tamper with the transformer, control box, motors, or remote control (with the exception of battery compartments). The product warranty will be void if these components are tampered with.

SMALL CHILDREN AND PETS:

Immediately dispose of all packing materials as they can smother small children and pets. Do not allow any person or pets under the bed. Children, convalescents and disabled persons should not operate the bed without adult supervision.

HOSPITAL OR CONVALESCENT USE DISCLAIMER:

Adjustable beds are designed and engineered for a lifestyle of in-home comfort and are not intended for hospital use or for a bed-ridden patient on an extended recovery. Adjustable beds are not equipped with bars to help patients get safely in and out of bed and are not intended to be used around tent type oxygen therapy or explosive gases.

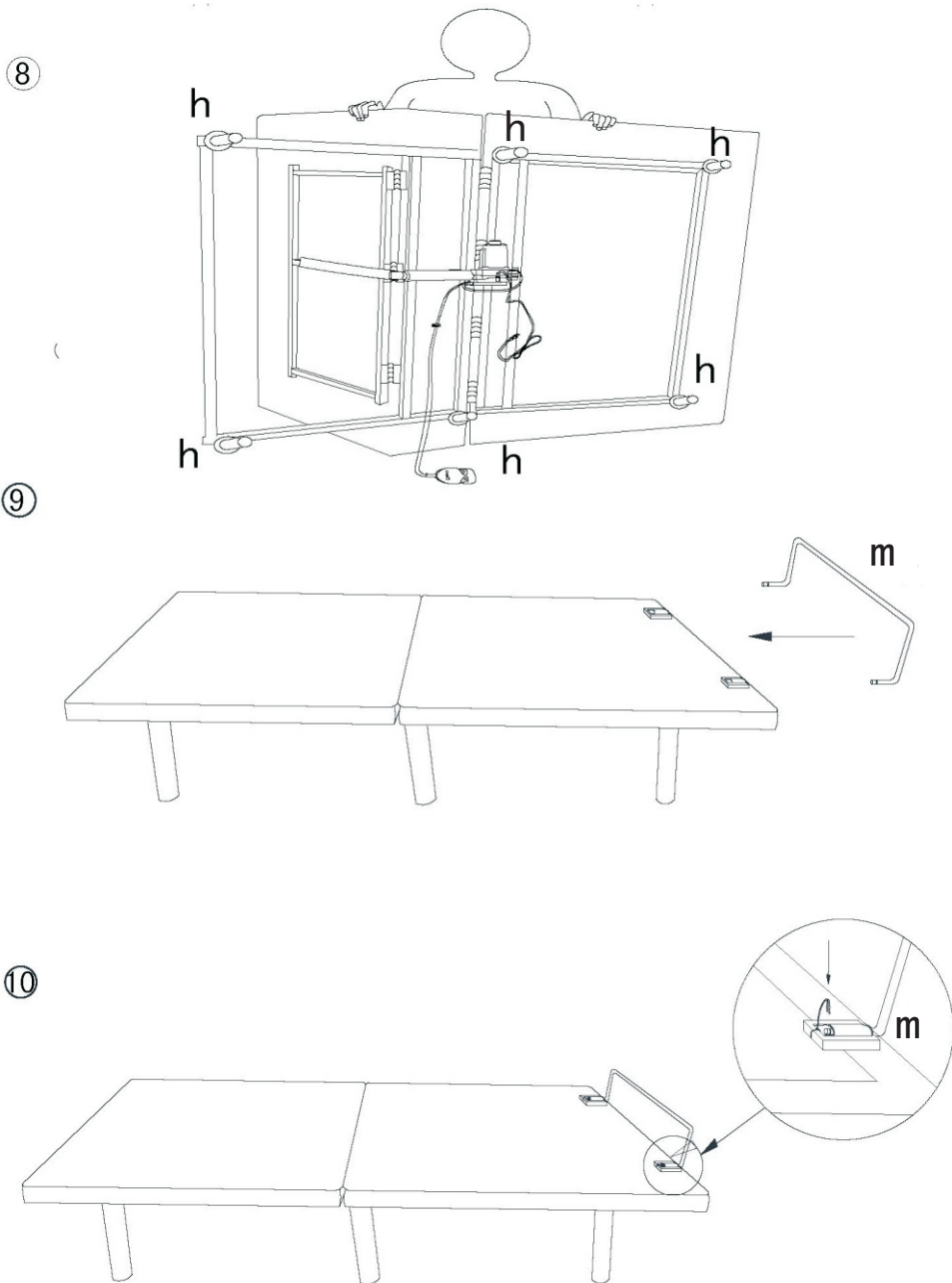

PRODUCT RATINGS:

The bed lift motors are not designed for continuous use of more than 2 minutes in an 18 minutes period, or approximately 10% duty cycle. Any attempt to circumvent or exceed this rating will shorten the life expectancy of the product and may void the warranty.

WEIGHT UNITS:

The limitation for this adjustable bed is 750 lbs. The bed will structurally support these weights, provided the bed is evenly distributed across the head and foot sections. This product is not designed to support or lift this amount in the head or foot section alone. Exceeding this weight restriction could damage the bed and /or cause injury and void the warranty. Enter or exit the bed in a flat position and do not sit on the head or foot sections while in the raised position.

LIFTING AND LOWERING MECHANISMS:

It is normal for the raising and lowering feature on this bed to emit a minimal humming sound during operation.

LOCATION ENVIRONMENT:

The level of sound experienced in a room is directly related to the environment within that location. To reduce the resonance, place a piece of carpet or rubber caster cups under the legs. The rubber caster cups also prevent the bed from sliding when located on smooth or hard surface flooring.

TO REDUCE THE RISK OF SHOCK, BURNS, FIRE OR INJURY:

Make sure the base is in a flat position before unplug from power source. Always unplug the base from the electrical outlet before cleaning or servicing the base. If the cord or plug is damaged, discontinue use of the bed base and contact qualified service personnel for examination and repair.

SETUP and INSTALLATION

Important: We strongly recommend two able-bodied adults to setup and assemble this product.

Step 1:
Check and verify all parts are included before discarding any packing materials.

Step 2:
With the help of your able-bodied assistant, place carton on floor with arrows pointing downwards. Assembly instruction details are on page 11 to page 14.

WE STRONGLY RECOMMEND: In order to help protect your investment in case of a power surge or outage, use an electrical surge protection device with a battery backup system (not included) then plug it in to a grounded outlet.

Step 3:
Plug electrical cord into a grounded electrical outlet.
Using the Wired Remote, push the Head Up button, for a momentary test.
NOTE; The actuator is a gravity down motor which needs weight to come down.

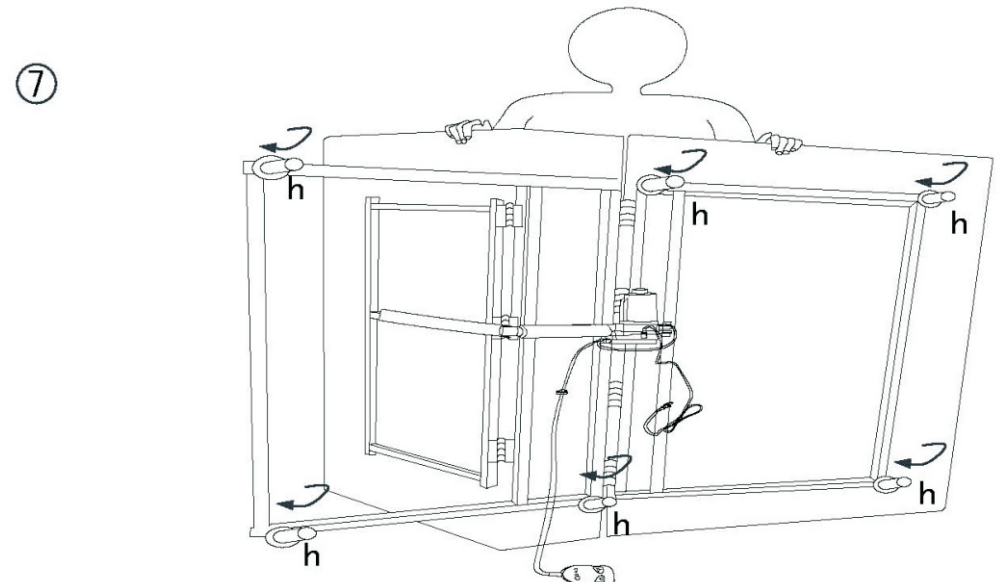
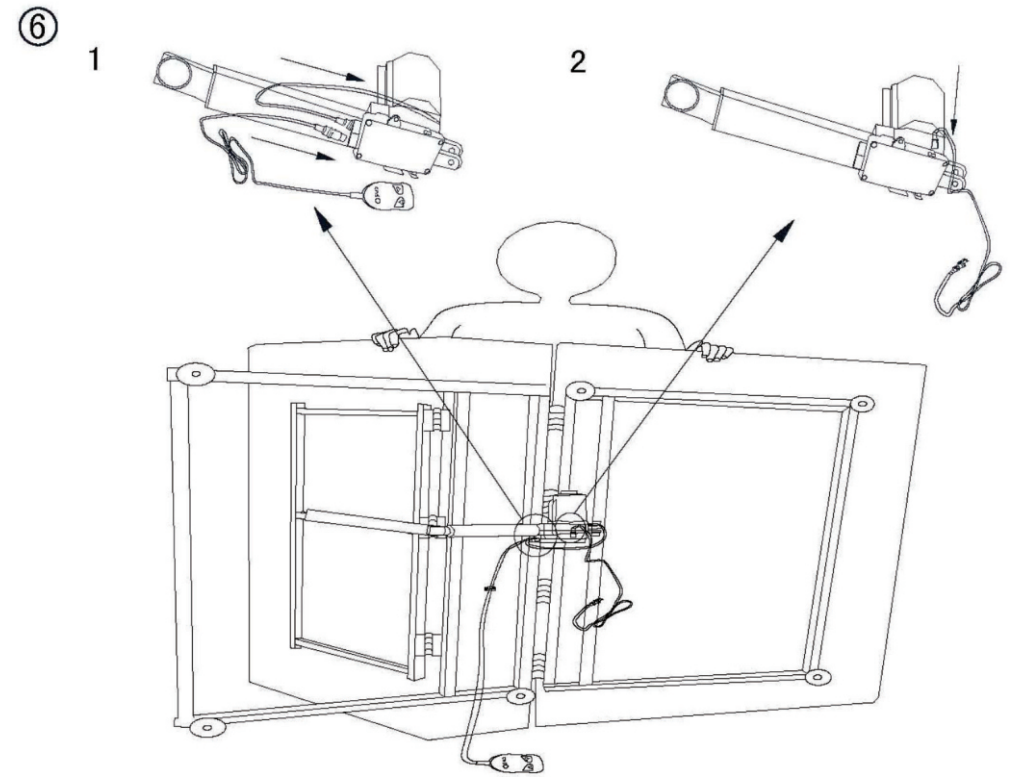

④

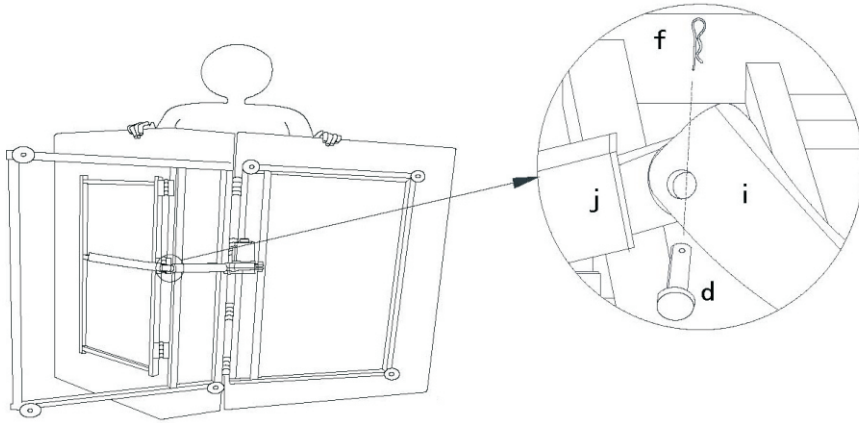

Step 4:

Unplug the Power Cord.

Install the six legs firmly into the base of the frame. The legs screw into the threaded holes in each corner of the adjustable base frame. (See Page 13).

-Do not over tighten

⑤

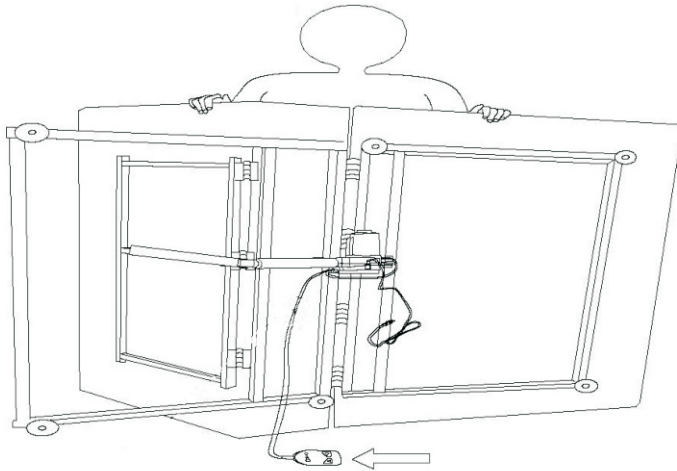

Step 5:

With the help of your able-bodied assistant, carefully lift the adjustable bed frame and set it in place upright on its legs. Excessive pressure may damage the legs. Remove all protective plastic covering.

Note: check and make sure that all power cords are clear and do not interfere with any Adjustable Bed Mechanisms. Dispose of covering properly to avoid injury.

Step 6:

Note: The Mattress Retaining Bar is attached to the bottom of the bed. Please install by carefully aligning and pushing the bar into place. Insert the retaining clips to secure the bar into place. (See Page 14.)

Setup is now complete. Plug it in and enjoy.



Wired Remote
#PB170 Adjustable Bed

Head Up Button
 Press To Raise The
 Head Of The Bed



Head Down Button
 Press To Lower The
 Head Of The Bed

For toll-free customer service, call 1-877-386-1373
 email us: service@innovasleep.com
 Please tell us your name, phone, address , serial No.
 (found on the foot beam of the bed),
 and the problem when you call/email.

Please Note : Put the bed base on the side before assembling it .

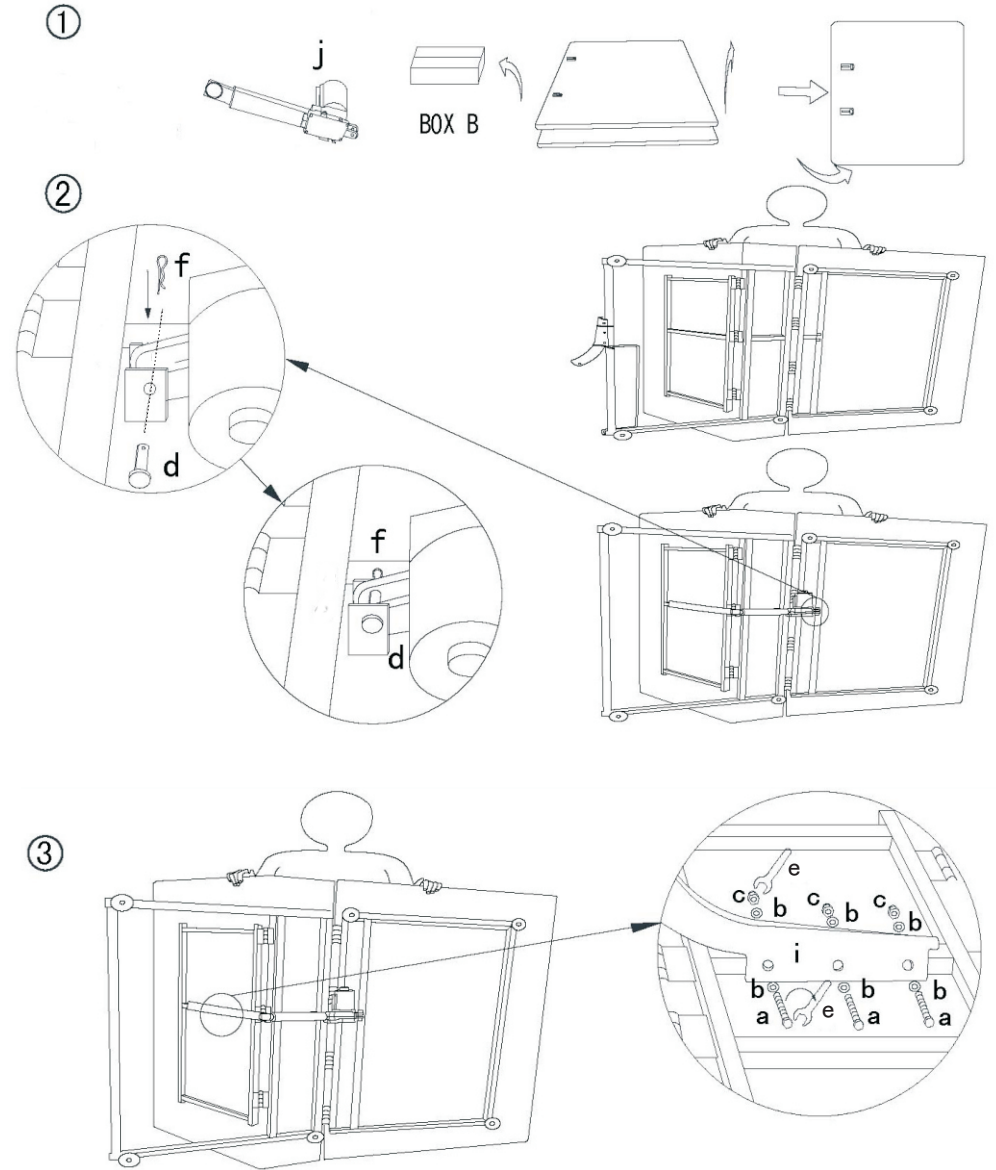









1, 2 & 20 YEAR LIMITED WARRANTY

Assembly Instruction

This product includes six boxes with box A, box B and three boxes C.

BOX B PARTS LIST

- | | |
|---|--|
| Ⓐ BOLT  3 PCS | Ⓑ STEEL WASHER  6 PCS |
| Ⓒ NUT  3 PCS | Ⓓ CLEVIS PINS  2 PCS |
| Ⓔ WRENCH  2 PCS | Ⓕ COTTER PINS  2 PCS |
| Ⓖ REMOTE CONTROL  1PCS | Ⓗ ACTUATOR  1 PCS |
| Ⓙ POWER CORD  1 PCS | |

- BOX A PARTS LIST Ⓘ  1 PCS Ⓜ  1 PCS

- 3 BOX C PARTS LIST Ⓢ STEEL LEG  6 PCS

Innova Sleep Systems, Inc. (“Innova”) warrants this adjustable bed to the consumer who is the original purchaser (the “purchaser”), subject to the terms and conditions set forth herein. This warranty begins on the “warranty commencement date” which is the date of purchase for new unused beds and the date of manufacture for beds that have been used as floor or display models. Thus, on a floor model bed, the warranty is a portion of the limited 20 year warranty.

FULL 1 YEAR WARRANTY

This adjustable bed is warranted against defects in the workmanship or materials for a period of one (1) year from the warranty commencement date. Upon notice during the first year after the warranty commencement date, Innova will repair or replace (at no cost to the purchaser) any defective adjustable bed part, and INNOVA will pay all authorized labor and transportation costs associated with the repair or replacement of any parts found to be defective. When the adjustable bed at hand is found to be DAMAGED, not DEFECTIVE, all costs incurred to inspect and/or correct the requested issue will be the financial responsibility of the requesting party.

2 YEAR LIMITED WARRANTY

During the second year from the warranty commencement date, upon receipt of written notice, INNOVA will replace any adjustable bed part found to be defective. Purchaser shall pay all service and transportation costs related to the replacement of the defective part. This limited two (2) year warranty shall not apply unless the defective part is returned to INNOVA and INNOVA receive all service and transportation cost for validation.

20 YEAR LIMITED WARRANTY

Upon written notice during the third year through the 20th year from the warranty commencement date, INNOVA will replace, upon term and conditions set forth in this paragraph, any mechanical bed part found to be defective. Electronics, electrical components, drive motors and massage motors are excluded. This limited warranty shall not apply unless the defective part is returned to INNOVA and INNOVA receive all service and transportation cost for validation. In years 3 - 20 years, purchaser shall pay all service and transportation costs related to the replacement of the defective part and required to pay 1/20 of the current replacement cost of the parts times the number of year used.

ADDITIONAL TERMS AND CONDITIONS

This warranty does not apply; (a) to any damage caused by the purchaser; (b) if there has been any repair or replacement of adjustable bed parts by an unauthorized person; (c) if the adjustable bed has been mishandled (whether in transit or by other means), subjected to physical or electrical abuse or misuse, or otherwise operated in any manner inconsistent with the operation and maintenance procedures outlined in the Owner's Manual and this warranty; (d) to damage to mattresses, fabric, cables, electrical cords or items supplied by dealers. Contact the dealer for warranty information on these items; (e) if there has been any modification of the adjustable bed without prior written consent by Innova; (f) to costs for unnecessary service calls, including costs for in-home service calls solely for the purpose of education the consumer about the adjustable bed or finding an unsatisfactory power connection; (g) if the recommended weight restriction is not followed (refer to the advisory section of this manual), the warranty will be void. Repairs to or replacement of an adjustable bed or its components under the terms of this limited warranty will apply to the original warranty period and will not serve to extend such period. The decision to repair or to replace defective parts under this warranty shall be made, or cause to be made, by INNOVA at its option and in its sole discretion. Repair or replacement shall be the sole remedy of the purchaser. There shall be no liability on the part of Innova for any special, indirect, incidental, or consequential damages or for

any other damage, claim, or loss not expressly covered by the terms of this warranty. This limited warranty does not include reimbursement for inconvenience, removal, installation, setup time, loss of use, shipping, or any other costs of expenses, Innova and/or its service technicians shall not be responsible for moving furniture or any other items not attached to the adjustable bed in order to perform service on the adjustable bed. It is the sole responsibility of the purchaser to provide adequate space and accessibility to the adjustable bed. In the event that the technician is unable to perform service due to lack of accessibility, the service call will be billed to the purchaser and the service will have to be rescheduled. Innova makes no other warranty expressed or implied, and all implied warranties of merchantability and fitness for a particular purpose are disclaimed by Innova and excluded from this agreement. Some states do not allow the exclusion or limitation of incidental or consequential damages, so the above limitation or exclusion may not apply to every purchaser. This warranty gives the purchaser specific legal rights, and the purchaser may also have other rights, which may vary from state to state. This warranty is valid in all 50 states, Puerto Rico, and Canada.